

HDPE flexible bends and uPVC long radius bends

There are two types of bends available for use with **Kabelflex** cable conduit, flexible HDPE bends and rigid long radius uPVC bends.



HDPE flexible bends

These bends are flexible and can be bent easily by hand to any angle or radius to suit one's requirements. They are supplied complete with one fitted push-fit coupling, and optional rubber sealing rings. A variety of colours are available to match the conduit.



Kabelflex conduit size
Nominal outside diameter mm
Overall length mm (<i>l</i>)
Bending radius mm (<i>r</i>)
Bend angle ° (α)
Belled ends
Push-fit coupling fitted
Rubber sealing rings

	HDPE flexible bends				uPVC long radius rigid bends			
	DN50	DN75	DN110	DN160	DN50	DN75	DN110	DN160
Not required		75	110	160	50	75	110	160
conduit		1700	1750	1800	500	700	1000	1200
only supplied		≥ 250	≥ 350	≥ 450	250	300	500	600
in coils		variable	variable	variable	22°, 45°, 90°	22°, 45°, 90°	22°, 45°, 90°	22°, 45°, 90°
		•	•	•	•	•	•	•
		optional	optional	optional	optional	optional	optional	optional

uPVC long radius rigid bends

These bends are available in 3 angular configurations 22°, 45° and 90°. They are supplied with both ends belled and are only available in black. Special bends can be manufactured on request.

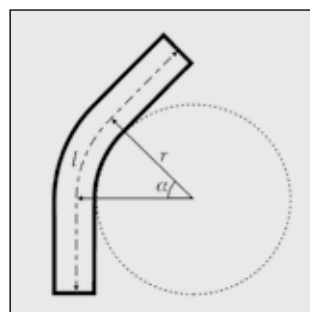

Nextube (Pty) Ltd

Tel : +27 (0)11 708 1659
Fax : +27 (0)11 708 2192
Email : info@nextube.co.za
Web : www.nextube.co.za



All specifications are subject to manufacturing tolerances